

Hand Chain Hoist

Model Code		HMCH05	HMCH1	HMCH2	
Capacity load	t	0.5	1	2	
Standard lift	m	3	3	3	
Running test load	t	0.75	1.5	3	
Load chain diameter	mm	6	6	8	
Dimensions	mm	A	131	140	161
		B	127	158	187
		C	270	317	414
		D	35	35.5	42.5
		K	30	28	33.5

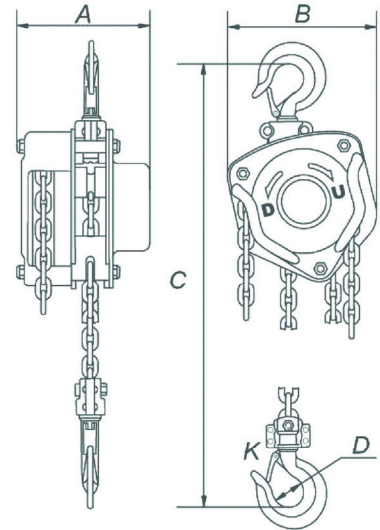

Chain Lever Hoist

Model Code		HMLH075	HMLH015	HMLH030	
Capacity load	t	0.75	1.5	3	
Standard lift	m	1.5	1.5	1.5	
Running test load	kN	11.0	22.5	37.5	
Effort required to lift max load	N	140	220	300	
No. of load chain falls		1	1	1	
Load chain diameter	mm	6	8	10	
Dimensions	mm	A	145	175	203
		B	86	100	118
		C	122	130	150
		D	37	45	50
		H	320	380	480
		L	280	410	410
		K	30	36	40

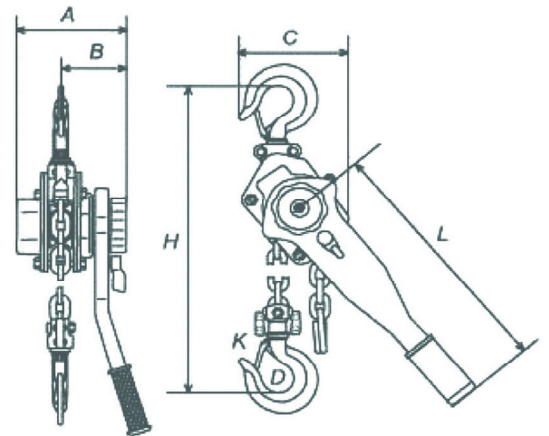

Distributed by: