



Loadsafe Lever Hoists

Capacities: 750kg to 9 tonnes

FEATURES

- Robust all-steel construction
- Super strength alloy loadchain
- Minimum effort to raise maximum load
- Fully enclosed gear train
- Weather protected automatic Weston brake
- Fully machined liftwheel
- Cast steel safety latches
- Malleable hook forgings
- All gears and shafts running on roller bearings or bushes
- Durable baked enamel paint protection
- Stainless Steel labels
- Spare parts always available

Loadsafe Lever Hoists are fitted with an overload - activated clutch which protects the operator from injury and the hoist from damage. Should an overload occur, the hoist will automatically stop transmitting the load, warning the operator to either reduce the load or select a hoist with a higher lifting capacity. Even when clutch is activated the load can be transmitted in the "DOWN" direction.

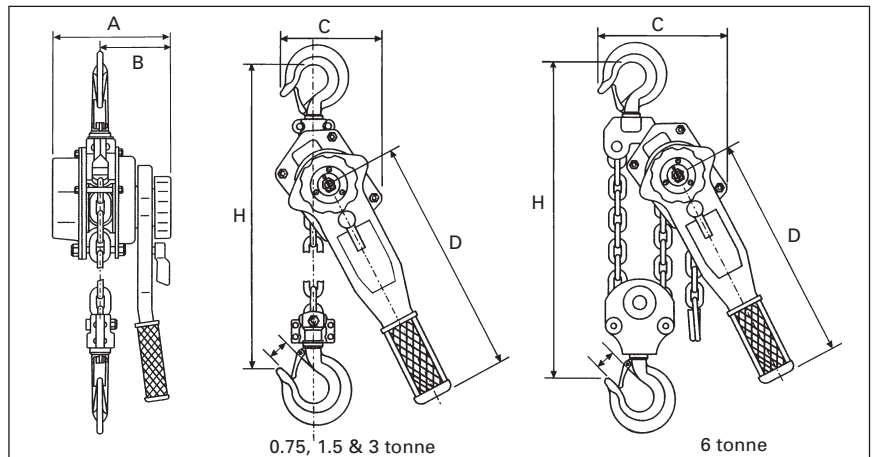

Product Code		SOLB075LS	SOLB150LS	SOLB300LS	SOLB600LS	SOLB900LS
Working Load Limit	Tonnes	0.75	1.5	3	6	9
Standard Lift	m	1.5	1.5	1.5	1.5	1.5
Test Load	kN	11.3	22.5	45	90	135
Headroom H	mm	325	380	480	620	700
Effort on lever to lift full load	kg	14	22	32	34	36
No. of load chain falls		1	1	1	2	3
Diameter of load chain	mm	6	8	10	10	10
Length of lever handle: D	mm	280	410	410	410	410
Clearance	mm	A	148	172	200	200
		B	90	98	115	115
		C	136	160	180	235
		E	30	35	40	50
Net Weight	kg	7	11	21	31	47

COMPLIES WITH AS/NZS1418.2

Meets or exceeds all relevant world standards