



Hand Chain Hoist

Capacity: 250kg

FEATURES

- Lightweight robust construction
- Chrome plated covers
- Super strength alloy loadchain
- Minimum headroom
- Thrust race in lower hook
- Fully enclosed gear train
- Galvanised hand and loadchain
- Minimum effort to lift W.L.L.
- Spare parts always available

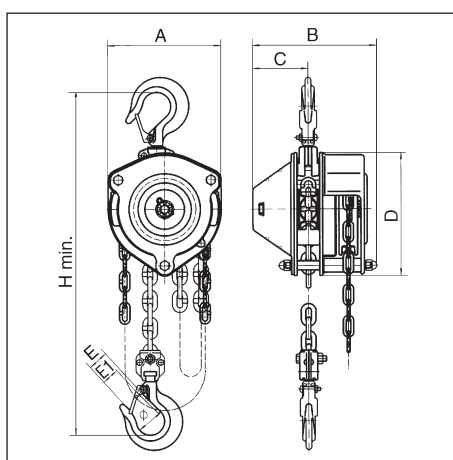

Model		OMCB025
W.L.L.	tonnes	0.25
Lift	m	2
Test load	t	0.375
Headroom (hook to hook) H min.	mm	230
Effort to lift full load N	kg	12
No. of load chain fall lines		1
Load chain (dia. x pitch)	mm	ø4 x 12
Dimensions mm	A	100
	B	110
	C	48.5
	D	109
	E	18
	E1	15.5
	ø	25
Net weight	kg	3.5
Extra weight per metre of extra lift	kg	0.54

COMPLIES WITH AS/NZS1418.2

Meets or exceeds all relevant world standards