



'S' Series Chain Hoists

Capacities: 500kg to 30 tonnes

FEATURES

- Lightweight robust construction
- Super strength alloy loadchain
- Fully machined liftwheel
- Minimum headroom
- Minimum effort to raise maximum load
- Cast steel safety latches
- Lower hook complete with thrust race
- Fully enclosed gear train
- Weather protected automatic Weston brake with unique Twin Pawls
- Galvanised handchain as standard
- Durable baked enamel paint protection
- Stainless Steel labels
- Spare parts always available

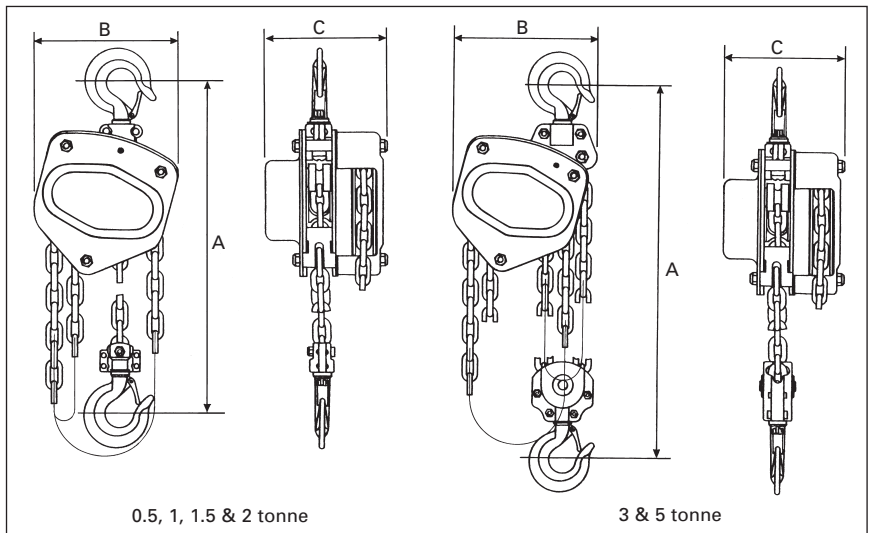

Chain Bags also available.

Product Code	SOCB05	SOCB1	SOCB1.5	SOCB2	SOCB3	SOCB5	SOCB10
Working Load Limit	0.5 t	1 t	1.5 t	2 t	3 t	5 t	10 t
Standard lift	3 m	3 m	3 m	3 m	3 m	3 m	3m
Falls of chain	1	1	1	1	2	2	4
Effort to lift W.L.L.	23 kg	30 kg	32 kg	35 kg	27 kg	41 kg	39 kg
Net weight	10 kg	12 kg	13 kg	22 kg	32 kg	46 kg	68 kg
Loadchain diameter	6 mm	6 mm	8 mm	8 mm	8 mm	10 mm	10 mm
CLEARANCE DIMENSIONS (mm)							
A (Headroom)	270	317	399	414	465	636	750
B (Width)	127	158	187	187	210	253	373
C (Depth)	131	140	161	161	161	161	184
Hook opening (upper)	30	28	36	33.5	40	50	64
Hook opening (lower)	30	28	36	33.5	40	50	64

• N.B. Specifications and dimensions for 20 & 30 tonne available on application.

COMPLIES WITH AS/NZS1418.2

Meets or exceeds all relevant world standards