



Lever Hoists

Capacities: 250kg and 500kg

FEATURES

- Lightweight robust construction
- Chrome plated covers
- Super strength alloy loadchain
- Minimum headroom
- Fully enclosed gear train
- Galvanised load chain
- Minimum effort to lift W.L.L.
- Spare parts always available

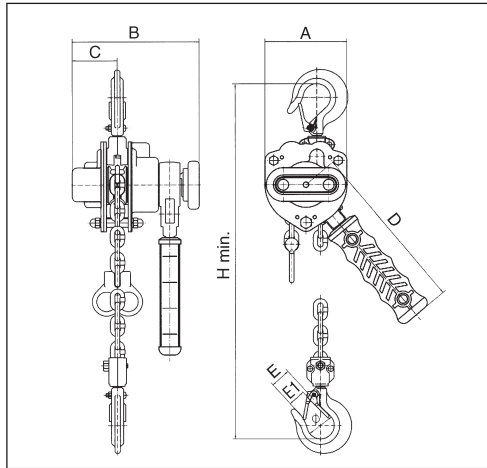

Model		OMLB025	OMLB05
W.L.L.	tonnes	0.25	0.5
Lift	m	1	1.5
Test load	t	0.375	0.75
Headroom (hook to hook)	H min. mm	215	255
Effort to lift full load	kg	13	18.5
No. of load chain fall lines		1	1
Load chain (dia. x pitch)	mm	ø4 x 12	ø5 x 15
Dimensions mm	A	75	90
	B	116	135
	C	41	51.5
	D	157	180
	E	18	24
	E1	15.5	21
	ø	25	32
Net weight	kg	2	3.5
Extra weight per metre of extra lift	kg	0.35	0.55

COMPLIES WITH AS/NZS1418.2

Meets or exceeds all relevant world standards



SYDNEY
 Phone: (02) 9531 8033
 Fax: (02) 9531 7933
 Email: sales@hesnsw.com.au
 www.hesnsw.com.au

MELBOURNE
 Phone: (03) 9480 5577
 Fax: (03) 9480 0855
 Email: sales@hesvic.com.au
 www.hesvic.com.au

ADELAIDE
 Phone: (08) 8244 7611
 Fax: (08) 8244 7699
 Email: sales@schillings.com.au
 www.schillings.com.au

PERTH
 Phone: (08) 9355 4218
 Fax: (08) 9472 7970
 Email: sales@heswa.com.au
 www.heswa.com.au

