

Ti TAN Electric Builder's Hoist

PRODUCT USAGE

The Electric Builder's Hoist is designed for building sites and various construction workplaces such as warehousing, buildings, storage areas, elevator liftwell maintenance, factories in general, as well as domestic applications.

FEATURES

- Compact and lightweight design which allows easy mounting.
- Automatic stop switch to avoid over-winding of the rope.
- A reverse-winding limit lever.
- Double safety brake device including an electromagnet brake for instant braking.
- Operates on single phase 240 volt power supply.
- 360° universal joint saddle with safety hook.
- Hand held control pendant with safety switch.
- Optional mounting arm bracket.
- Spare parts available.

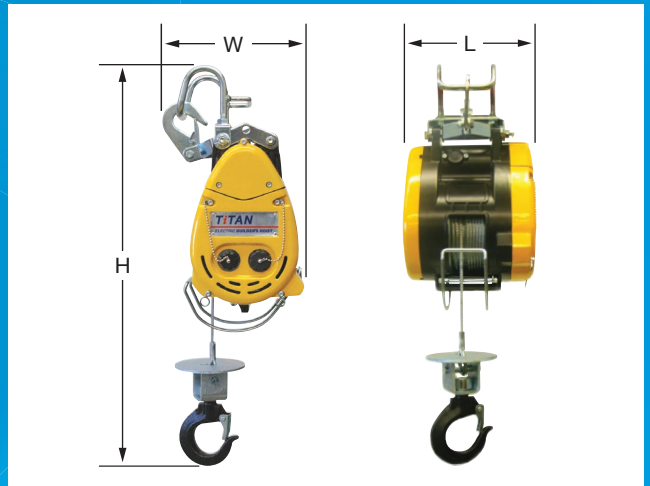

Model Code		TBH-160A	TBH-230A	TBH-300A
Length (L)	mm	240	240	240
Width (W)	mm	180	180	210
Height (H)	mm	660	660	670
Capacity	kg	160	230	300
Safety Factor		WLL x 1.5	WLL x 1.5	WLL x 1.5
Standard Lift		30	30	30
Motor Power/amps		1.2 / 6	1.3 / 7	1.3 / 8
Lifting speed	m/min.	23	23	15
Wire rope	mm	5mm 7 x 19	5mm 7 x 19	5mm 7 x 19
Minimum Grade Wire Rope		G1900 IWRC	G1900 IWRC	G1900 IWRC
Continuous usage rate p/hr (min)		15	15	15
No. of starts per hour		300	300	300
Control cable	m	5	5	5
Net weight	kg	15	16	20

Ti TAN
LIFTING TECHNOLOGIES

Cnr. Chifley Drive & Fink Street
Preston Victoria 3072 Australia
Phone +61 3 9480 6063
Fax: +61 3 9480 6065
Email: sales@titanlifting.com

Ti TAN Electric Builder's Hoist

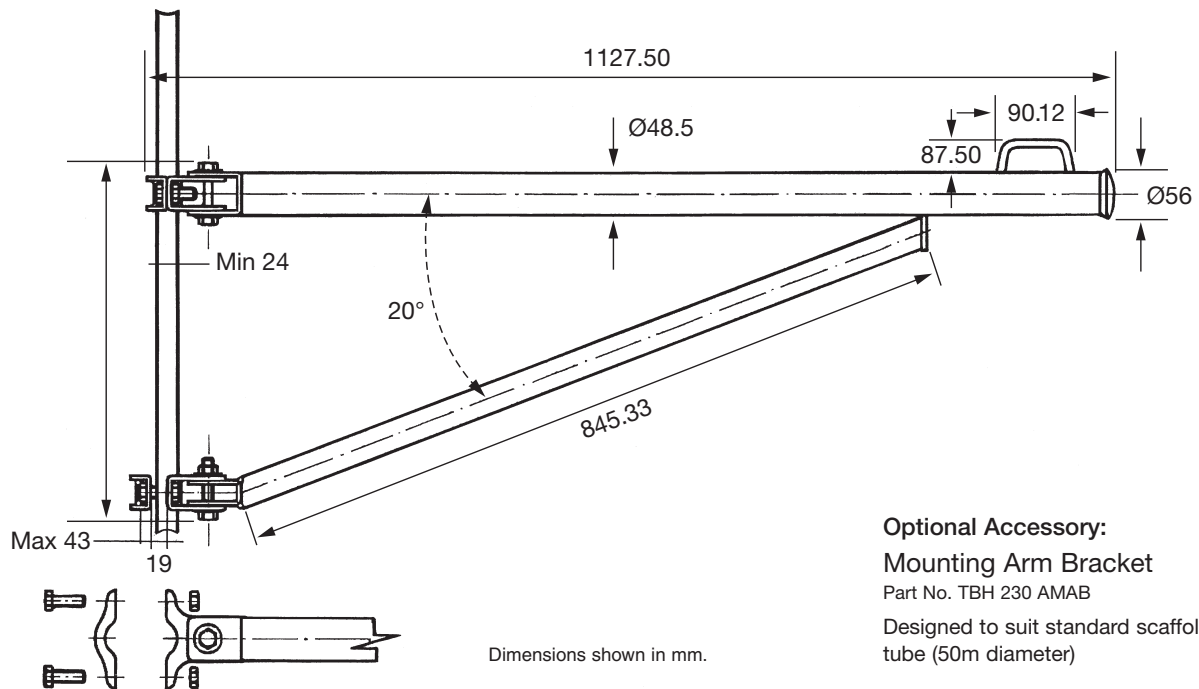

Optional Accessory:
Mounting Arm Bracket
 Part No. TBH 230 AMAB
 Designed to suit standard scaffold tube (50mm diameter)

Main Spare Parts Range:



Power Cable
 Part No. TBH-230APC



Control Pendant
 Part No. TBH-230ACP



Latch Kit
 Part No. TBH-230ALK
 Lower Hook
 Part No. TBH-230ALH

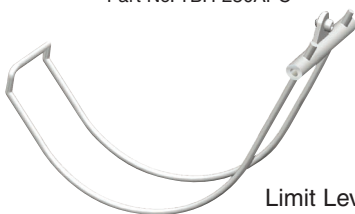

Limit Lever Assembly
 Part No. TBH-230ALL

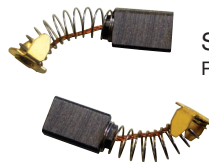

Set of Brushes
 Part No. TBH-230ABS

Other spare parts available on request.

Distributed by:

Ti TAN
LIFTING TECHNOLOGIES

Cnr. Chifley Drive & Fink Street
 Preston Victoria 3072 Australia
 Phone: +61 3 9480 6063
 Fax: +61 3 9480 6065
 Email: sales@titanlifting.com