



Combined Hoisting Assembly

'S' Series Chain Block Close Coupled to Push or Geared Girder Trolley

Capacities: 1 tonne to 5 tonnes

FEATURES

- Hoist and trolley integrated offers minimum headroom and theft protection
- Robust all steel construction
- Minimum effort to raise load
- Super strength alloy steel chain
- Stainless steel name plates
- Durable baked enamel paint protection
- Weather protected Weston brake
- Cast steel safety latches
- Spare parts always available
- Overload protection offered as optional extra

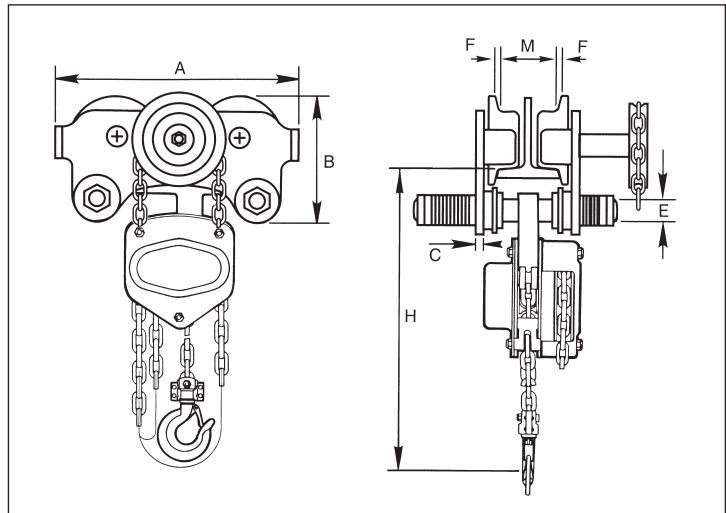

Product Code	OCHRG1/0	OCHRG2/0	OCHRG3/0	OCHRG5/0
Rated Capacity tonnes	1	2	3	5
Test load kN	15	30	45	75
Min. radius m	1	1.2	1.4	1.6
Pulling force to lift full load N	40	70	65	100
Standard Lift m	3	3	3	3
Dimensions mm	A	277	302	363
	B	170	194	230
	C	10	12	14
	D	283	295	304
	E	M22	M27	M30
	F	≈3	≈3	≈3
Beam width mm	58-180	58-180	74-180	98-180
Min. headroom H mm	375	438	593	741

COMPLIES WITH AS/NZS1418.2

Meets or exceeds all relevant world standards

LIFTING & HOISTING LIFTING & HOISTING



SYDNEY
 Phone: (02) 9531 8033
 Fax: (02) 9531 7933
 Email: sales@hesnsw.com.au
 www.hesnsw.com.au

MELBOURNE
 Phone: (03) 9480 5577
 Fax: (03) 9480 0855
 Email: sales@hesvic.com.au
 www.hesvic.com.au

ADELAIDE
 Phone: (08) 8244 7611
 Fax: (08) 8244 7699
 Email: sales@schillings.com.au
 www.schillings.com.au

PERTH
 Phone: (08) 9355 4218
 Fax: (08) 9472 7970
 Email: sales@heswa.com.au
 www.heswa.com.au

